

IFU PRINTING SPECIFICATION SHEET

PAGE LAYOUT

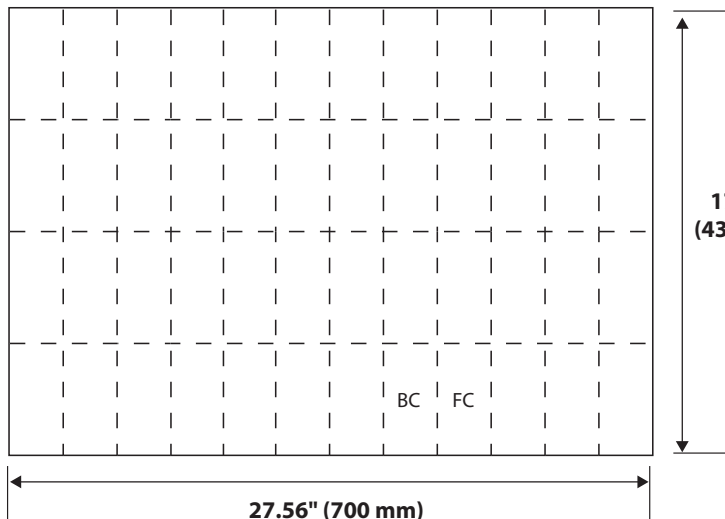

27.56" (700 mm)

Flat Size

FOLD PATTERN

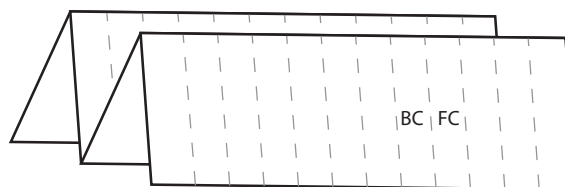

17.28"
(439 mm)

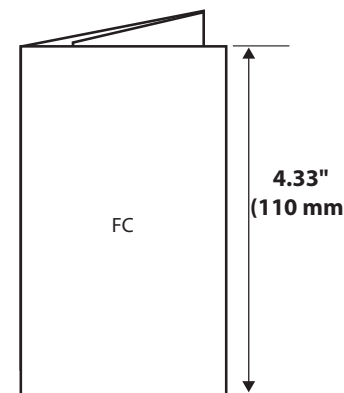
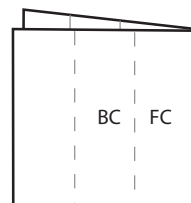
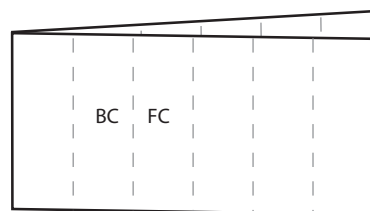

4.33"
(110 mm)

2.30" (58.33 mm)

Folded Size

TITLE PDS™ II		DESCRIPTION Map IFU		LAB NUMBER LAB0012226v5	SPECIAL INSTRUCTIONS/COMMENTS n/a		BINDING n/a	COLORS Black			
FLAT SIZE 27.56" x 17.28" 700 mm x 439 mm		FOLDED SIZE 2.30" x 4.33" 58.33 mm x 110 mm		RMC NUMBER 389806R04	PAGE COUNT 2	LANGUAGES ar, bg, cs, da, de, el, en, es, et, fi, fr, hr, hu, it, ko, lt, lv, mk, nl, no, pl, pt, ru, sk, sl, sr, sv, tr, zh-cn, zh-tw		SELF COVER <input checked="" type="checkbox"/>	PLUS COVER <input type="checkbox"/>	SEALING METHOD <input type="checkbox"/>	WAFER SEAL <input checked="" type="checkbox"/>
BLEED SIZE .5" (12.7 mm) .125" (3.175 mm) <input type="checkbox"/> <input type="checkbox"/>		NONE <input checked="" type="checkbox"/> BLEED ALL SIDES <input type="checkbox"/>		BLEED TOP <input type="checkbox"/>	BLEED RIGHT <input type="checkbox"/>	BLEED LEFT <input type="checkbox"/>	BLEED BOTTOM <input type="checkbox"/>				
STOCK Opakal white CF, 50 g/m²					DRAWING IS NOT TO SCALE: DRAWINGS REFLECT INFORMATION FOR PRODUCTION OF PRINTED PIECES AND DO NOT CONTAIN ACTUAL ARTWORK. This document or data herein or herewith is not to be reproduced, used or disclosed in whole or part without the permission of Ethicon, Inc.						
					ETHICON						